

VICTORIAN ONE INSTALLATION MANUAL

Effective January 1, 2014

Victorian One[®]



Customer Name: _____
Order#: _____

If you have any questions, please call the location that your Stair Kit was purchased from:

Broomall, Pennsylvania
Ontario, California

1-800-523-7427
1-800-382-IRON (4766)

Venice, Florida
Houston, Texas

1-800-648-6990
1-800-438-IRON (4766)

THE IRON SHOP[®]

The Leading Manufacturer of Spiral Stair Kits[®]

TABLE OF CONTENTS

VICTORIAN ONE SPIRAL KITS AND ACCESSORIES:

Guarantee & Safety	1
Introduction & Tools Required	2
Standard Victorian One Spiral Stair Kit Layouts	3
Basic Kit Components	4
Victorian One Spiral Stair Kit Assembly Procedure:	
Step #1 - Center Pole Base Flange	5
Step #2 - Center Pole & Landing	6
Step #3 - Top Tread & Spindle	7
Step #4 - Intermediate Treads & Spindles	8
Step #5 - Bottom Tread & Spindle	8
Step #6 - Handrail (Aluminum or Brass)	9
Step #7 - Handrail Scroll Ends	11
Step #8 - Landing Railing & Post	13
Step #9 - Finishing	14
Victorian One Spiral Stair Kit Accessories:	
Well Rails	15
Scroll Tread Ends	16
Solid Oak Handrail	17
In-Between Spindles	18
Balcony Railing	19

THE IRON SHOP®

The Leading Manufacturer of Spiral Stair Kits®

GUARANTEE & SAFETY

GUARANTEE

The Iron Shop guarantees the Victorian One Spiral Stair Kit against defective material and workmanship for a period of one year from the date of purchase. We will replace any part returned to us during that period at no cost. This guarantee is invalid if the installation was not completed in accordance with our assembly procedures or if the Stair Kit is abused or not maintained by the customer.

- Read the instructions thoroughly before starting the installation.
- Wear safety goggles and gloves during assembly.
- Prohibit use and access of the stair from the top and the bottom until the entire installation is complete.
- Protect all open sides of the well opening, or edge of the balcony or loft, with railings or partition walls to prevent anyone from falling into the stair well.
- Do not stand or walk on the stair until the entire installation of the stair has been completed.
- Some hardware may vary slightly from description due to manufacturing variations. However, this will not affect assembly. Please consult customer copies for hardware break down.
- It is the customer's responsibility to advise us of any and all building codes or special requirements for your Stair Kit from The Iron Shop. As manufacturers of quality stairs since 1931, we can design a stair to meet almost any requirements.
- Following these guidelines will provide you with many years of use and enjoyment of your Victorian One Spiral Stair Kit. Failure to do so will void your guarantee.

If you have any questions please do not hesitate to call us; see the front cover for our toll free phone numbers.

Safety Warning: *This stairway has an open grate design for the treads and landing. Do not permit the use of stair by persons wearing high heel shoes. (The pointed tip of the high heel could catch in an opening, causing the wearer to trip and fall!)*

THE IRON SHOP®

The Leading Manufacturer of Spiral Stair Kits®

INTRODUCTION & TOOLS REQUIRED

INTRODUCTION

The Iron Shop's Victorian One Spiral Stair Kit is manufactured and packaged by hand on an individual basis. We always do our very best to insure that each Kit is complete, if you should find that a part is missing please call us toll free at 1-800-523-7427 and we will take immediate action to correct the problem.

Before starting the installation of your Spiral Stair Kit, please read the instructions thoroughly to become familiar with all the components and procedures.

TOOLS NEEDED FOR INSTALLATION:

- Safety Goggles
- Tape Measure
- Framing Square
- Plumb Bob
- Level
- Hack Saw
- Phillips Head Screw Driver
- Adjustable Wrench or Socket Set
- Hammer & Small Block of Wood
- $\frac{3}{8}$ " Electric Drill and Extension Cord
- $\frac{1}{8}$ " Drill Bit
- $\frac{9}{64}$ " Drill Bit
- $\frac{5}{32}$ " Drill Bit
- $\frac{11}{64}$ " Drill Bit
- $\frac{7}{32}$ " Drill Bit
- $\frac{3}{8}$ " Masonry Drill Bit (Needed only for fastening baseplate to concrete or ceramic tile floor.)
- Ladder

THE IRON SHOP®

The Leading Manufacturer of Spiral Stair Kits®

STANDARD VICTORIAN ONE SPIRAL LAYOUTS

STANDARD VICTORIAN ONE SPIRAL STAIR KIT LAYOUTS

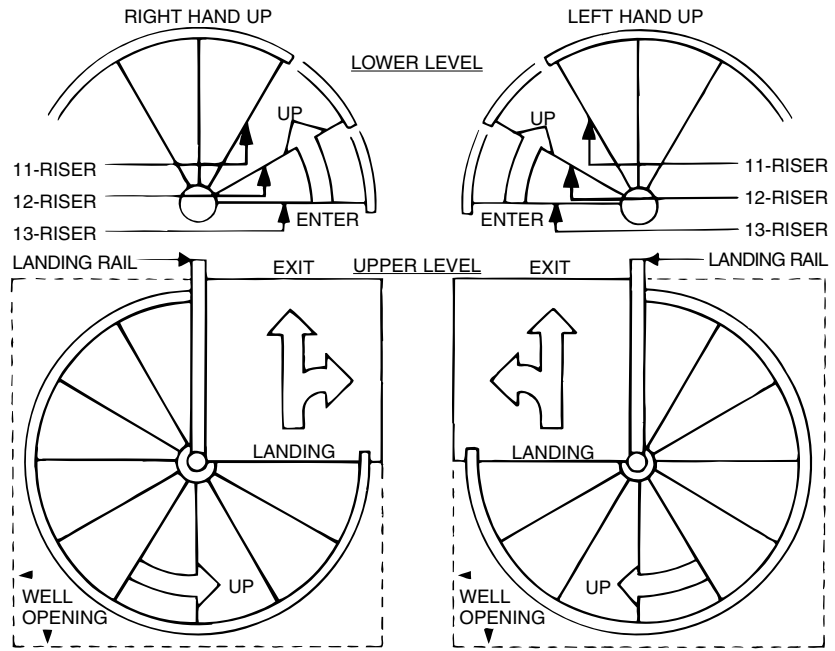

Important Note: Your Kit is custom cut to fit your floor-to-floor height. It is therefore extremely important that you supplied us with the exact finished floor to finished floor height. We also needed to know whether your stair will be assembled “left hand up” (handrail is to your left as you enter the stair from the lower level) or “right hand up” (handrail is to your right as you enter the stair from the lower level).

Minimum Finished Well Opening Requirements:
Carefully check your planned location to make certain you can provide at least the minimum well opening dimensions required for your stair diameter.

	<u>Finished Well Opening</u>
4'0" Diameter Stair	4'2" x 4'2" Minimum
5'0" Diameter Stair	5'3½" x 5'3½" Minimum
6'0" Diameter Stair	6'2" x 6'2" Minimum

Note: If a layout was provided by The Iron Shop for your specific installation, it should be used. If you have any layout questions, please call The Iron Shop location where the Kit was purchased prior to installation.



The Leading Manufacturer of Spiral Stair Kits®

BASIC KIT COMPONENTS

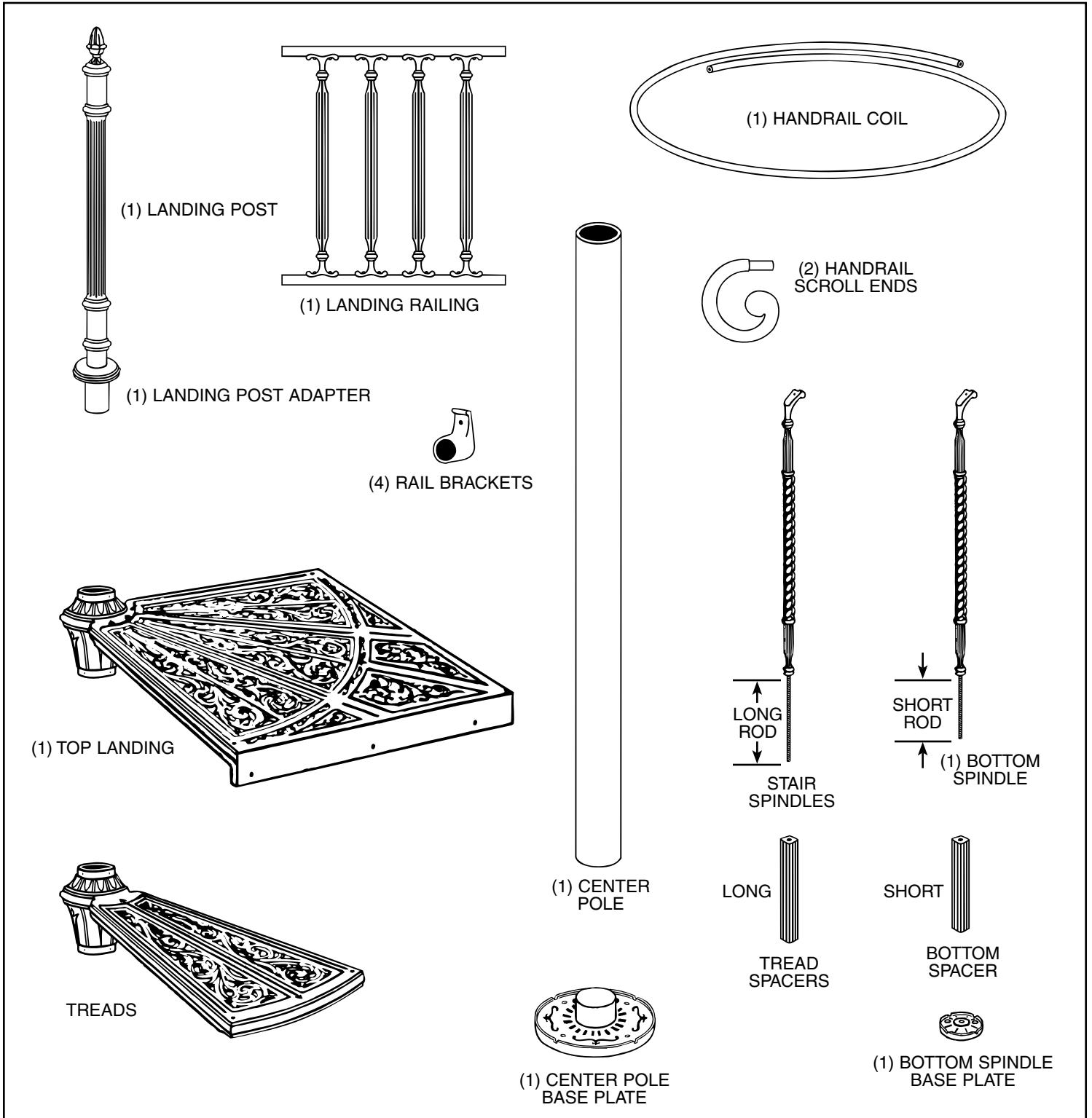

THE IRON SHOP®

The Leading Manufacturer of Spiral Stair Kits®

VICTORIAN ONE ASSEMBLY PROCEDURE

VICTORIAN ONE ASSEMBLY PROCEDURE

Note: The following instructions are for standard Kits only. Special order and non-standard Kits may require alterations. Call the location where the Kit was purchased with any questions regarding your installation.

Note: Spiral stairs are permitted to use riser heights up to 9½" (under most national building codes) to allow sufficient headroom.

STEP #1 - Center Pole Base Flange:

(A.) Check the corner where the landing will be installed with a framing square to make sure it is 90°. Measure out from the point of the corner 25" for a 4'0" diameter, 31" for a 5'0" diameter, or 37" for a 6'0" diameter stair. Pencil mark each point on the floor and the face of the opening. Using a plumb bob, locate the marked points and corner from the upper floor onto the floor below. Mark the plumb points with a pencil. **SEE DIAGRAM 1-A**

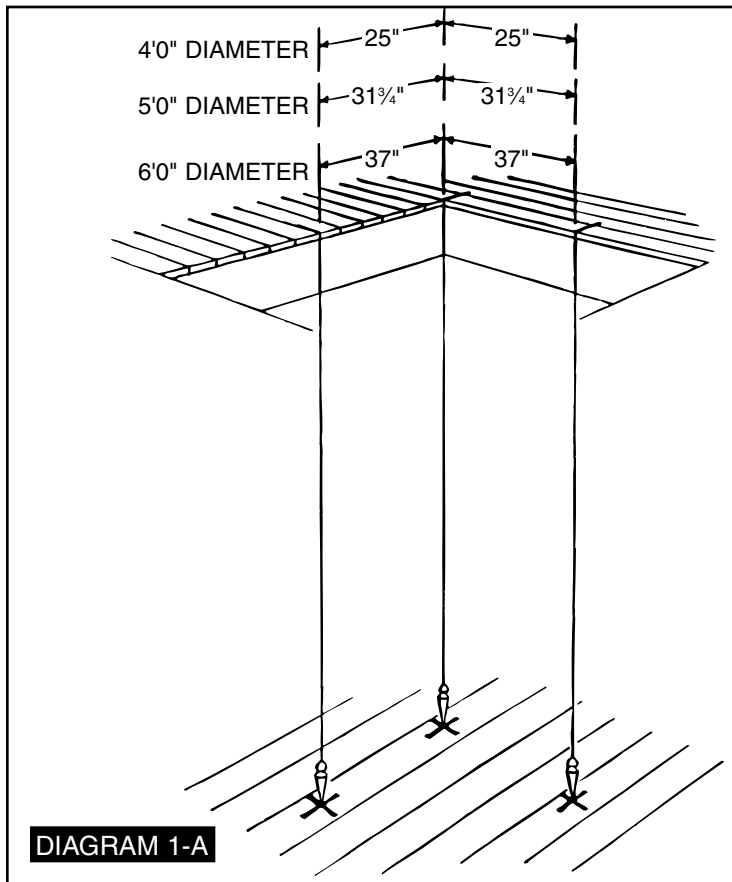

(B.) Draw a light line from the corner out to each point. Check to see that the angle formed is 90°. Using your framing square, draw 90° lines from the end point marks for the landing size. Let these lines cross and extend at least 8" beyond the point where they intersect. (This point is the center mark for the center pole base flange.) **SEE DIAGRAM 1-B**

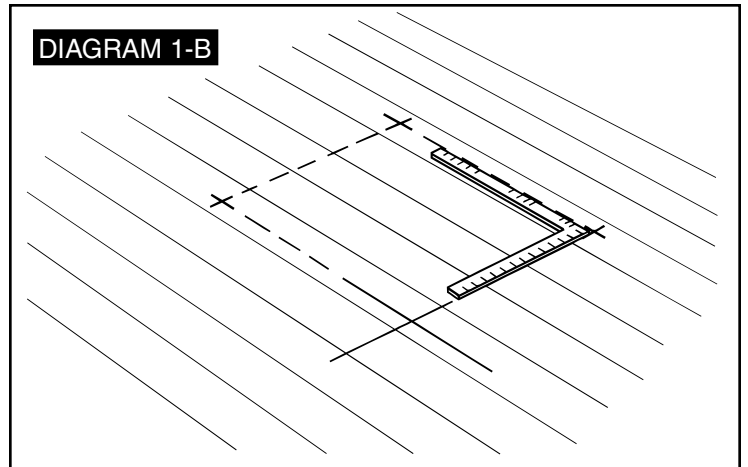

(C.) Place the center pole base flange on the "X" so it is centered in each direction. Trace the bolt holes on the floor. If your floor is wood, drill 7/32" pilot holes and then fasten the base flange with four 2" long lag bolts. If your floor is concrete, use a 3/8" carbide tip masonry drill bit and drill holes 2" deep. Clean out the holes and insert rawl fiber expansion plugs. Fasten the base flange with four 2" long lag bolts. **SEE DIAGRAM 1-C**

THE IRON SHOP®

The Leading Manufacturer of Spiral Stair Kits®

VICTORIAN ONE ASSEMBLY PROCEDURE

DIAGRAM 1-C

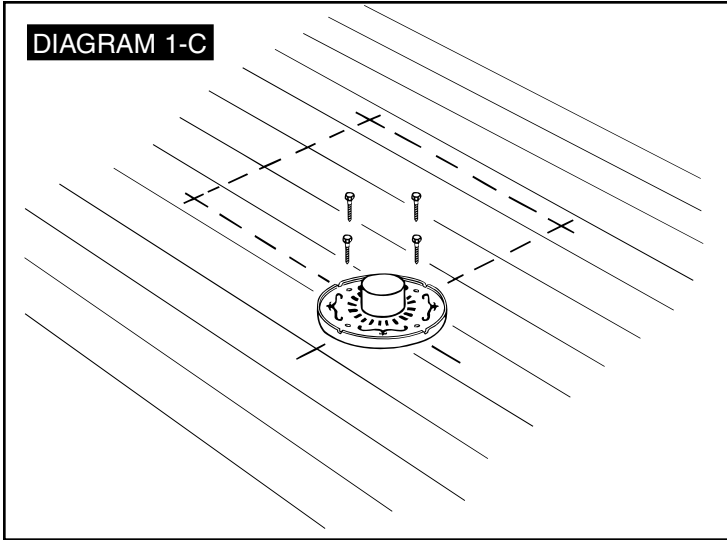

STEP #2 - Center Pole & Landing:

(A.) Stand the center pole up and slide the bottom end of the pole over the center plug sleeve of the base flange. Make sure it seats on the top of the flange. *SEE DIAGRAM 2-A*

DIAGRAM 2-A

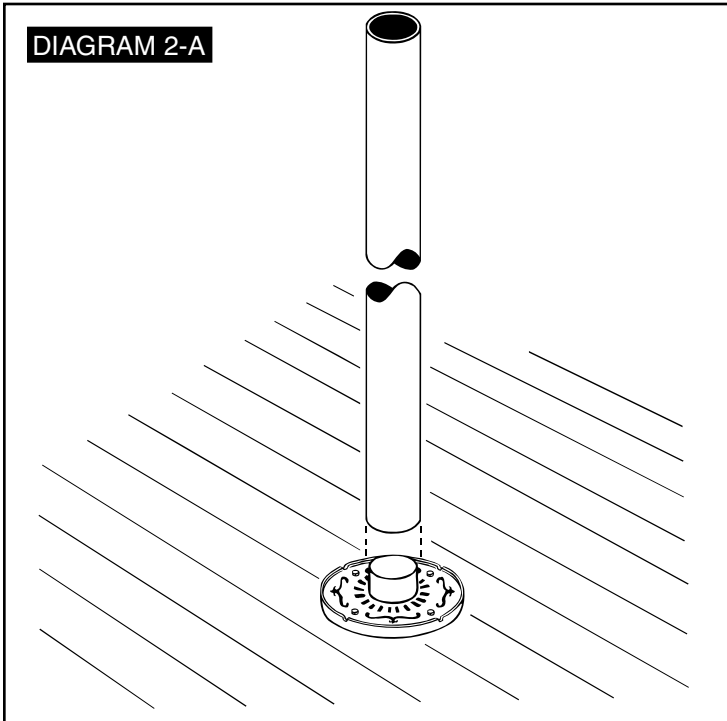

(B.) Carefully pass each tread over the top of the pole and lower to the base. (A third person is helpful during this procedure.) Let the first tread rest on the base flange and stack the following treads one on top of the

other. It is very important to stack the treads so that they alternate to opposite sides of the pole. Insert all set screws loosely into each hub. *SEE DIAGRAM 2-B*

DIAGRAM 2-B

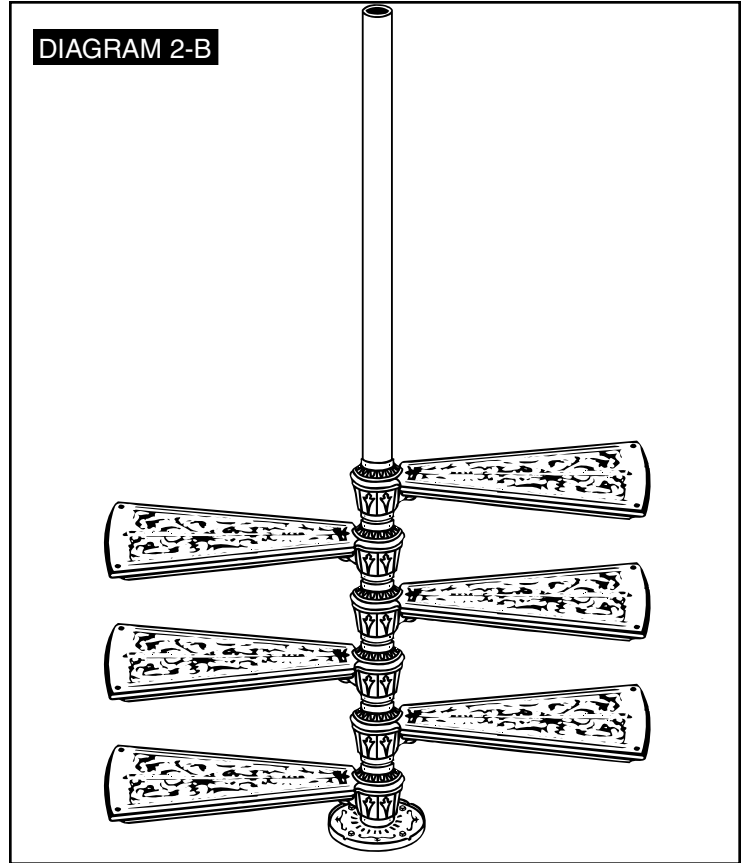

(C.) Insert set screws loosely into hub of the landing, taking care that they do not protrude on the inside of the hub. Carefully lower the landing so that it fits tightly into the corner (in which it is to be installed) and each side is flush and level with the top of the floor surface. *SEE DIAGRAM 2-C*

THE IRON SHOP®

The Leading Manufacturer of Spiral Stair Kits®

VICTORIAN ONE ASSEMBLY PROCEDURE

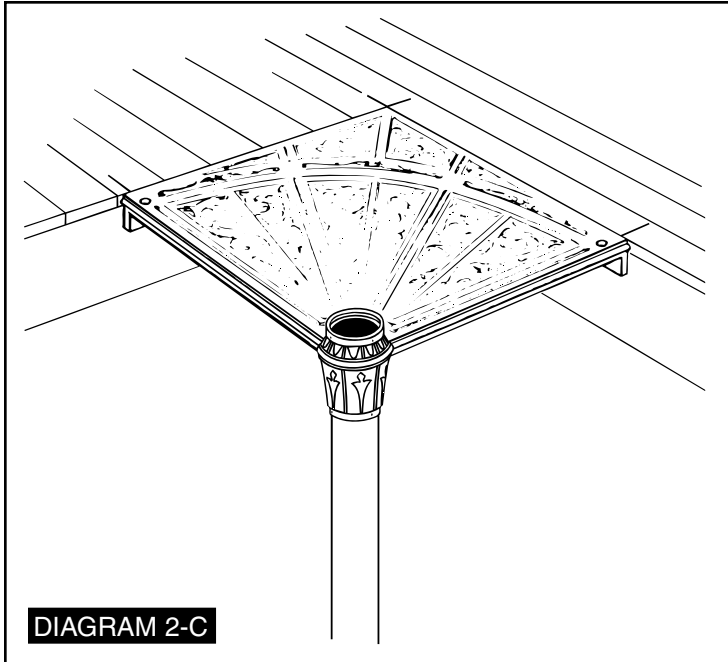

DIAGRAM 2-C

Tighten the top two set screws on the landing hub. Starting from the corner and working outward, drill pilot holes into the well opening framing (using the $\frac{7}{32}$ " bit) through the pre-drilled bolt holes in the landing side panels. Secure the landing in place using the six 3" long lag bolts. **Make sure the bolts go into solid wood.** Check the leading edges of the landing to assure they are level. (You may have to loosen the top set screws and adjust landing up or down.) Tighten all four set screws in the landing hub.

STEP #3 - Top Tread & Spindle:

(A.) Check your shop drawings to identify all stair spindles and tread spacers and their positions. **Be careful not to use the spindle designed for the base of the stair which has a shorter length of threaded rod extending from the bottom and uses the short tread spacer.**

Accessory Note: If you ordered your Kit with the optional balcony railing please refer to Page 19 for additional instructions.

Insert the threaded rod of the top railing spindle through the spindle hole in the leading edge of the landing, on the side from which you will be descending. **SEE DIAGRAM 3-A**

Raise the last tread that was lowered down the pole and position it so that the threaded rod of the spindle, with the tread spacer on it, will go through the rear spindle hole of the tread. Place a lock washer and an acorn nut on the threaded rod protruding below the tread and tighten lightly. **SEE DIAGRAM 3-A**

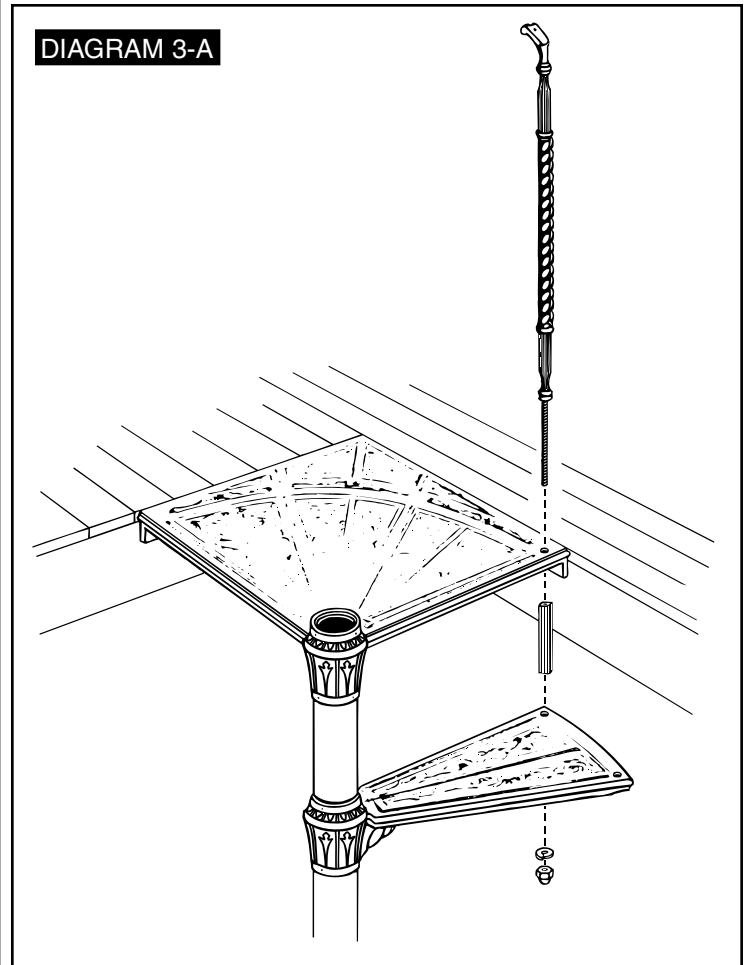

DIAGRAM 3-A

Accessory Note: If you ordered your Kit with the optional scroll tread ends please refer to Page 16 for additional instructions.

(B.) Check the spindle and tread spacer with your level to make sure they are plumb. Rotate the tread from front to back while plumbing. Also, position the tread spacer so that the fluting matches the design on the railing spindle. Make sure the spindle is positioned so that the handrail bracket is angled upward and is parallel to the outside edge of the tread. **SEE DIAGRAM 3-B**

THE IRON SHOP®

The Leading Manufacturer of Spiral Stair Kits®

VICTORIAN ONE ASSEMBLY PROCEDURE

Tighten the acorn nut under the tread and check to see that the tread is level. Raise or lower the hub if necessary to level the tread. When the tread is level, tighten the top two set screws making sure that the tread remains level, then tighten the bottom two set screws. **SEE DIAGRAM 3-B**

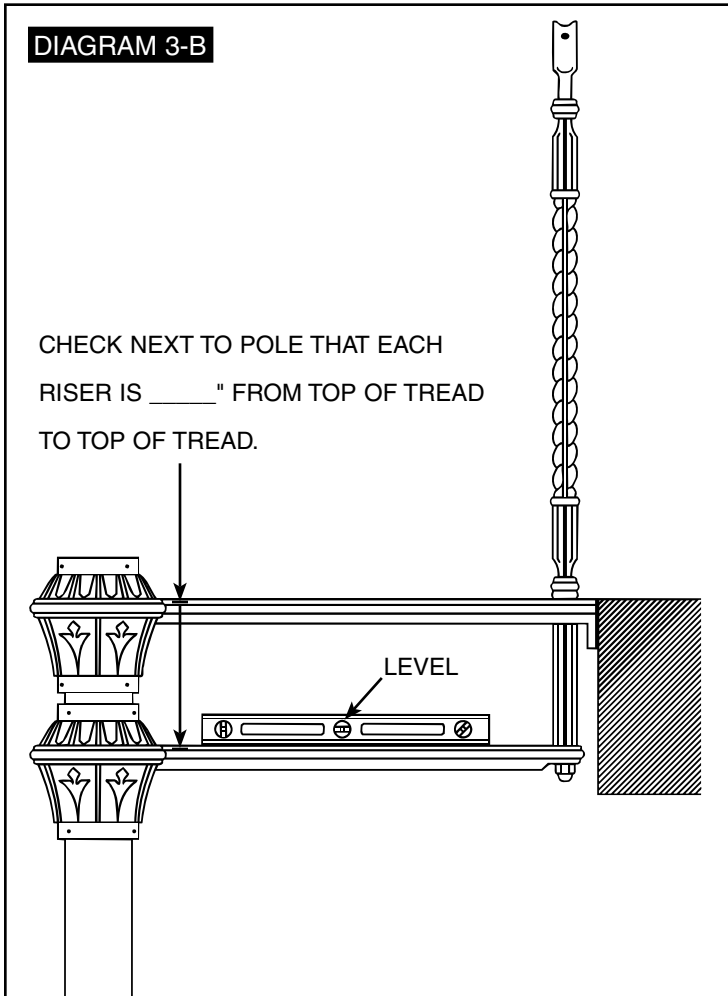

Note: DO NOT hit the tread or any other aluminum part directly with a metal hammer, as damage may result. If you need to use a hammer to tap the tread up or down, place a block of wood between the tread and the hammer.

STEP #4 - Intermediate Treads & Spindles:

(A.) Raise the next tread up the center pole and place the threaded rod of a regular railing spindle (long length of threaded rod) in the front spindle hole of the tread above. Place a tread spacer over the threaded rod and

pass the rod through the rear spindle hole of the tread. Place a lock washer and acorn nut and tighten lightly. **SEE DIAGRAM 4-A**

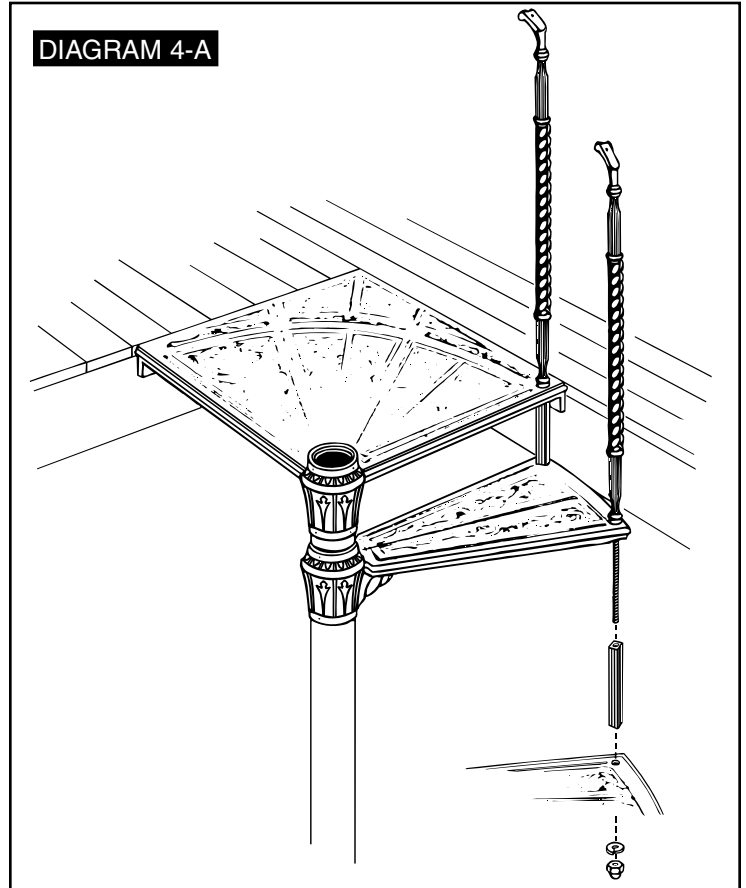

Repeat the leveling aligning procedures as covered in **STEP #3-B**.

(B.) Repeat the above procedure for each of the remaining treads except the bottom tread.

STEP #5 - Bottom Tread & Spindle:

Note: The bottom tread riser height may differ slightly from the previous treads set in place.

(A.) The bottom tread receives the spindle with the shorter threaded rod. Insert the rod through the front spindle hole of the bottom tread, bottom tread spacer and starting spindle base plate. Tighten and align into the base plate. Use your level to check that the spindle and spacer are plumb front to back and side to side. Also, make sure that the fluting on the spacer lines up



The Leading Manufacturer of Spiral Stair Kits®

VICTORIAN ONE ASSEMBLY PROCEDURE

with the design on the spindle and that the handrail bracket is properly aligned. **SEE DIAGRAM 5-A**

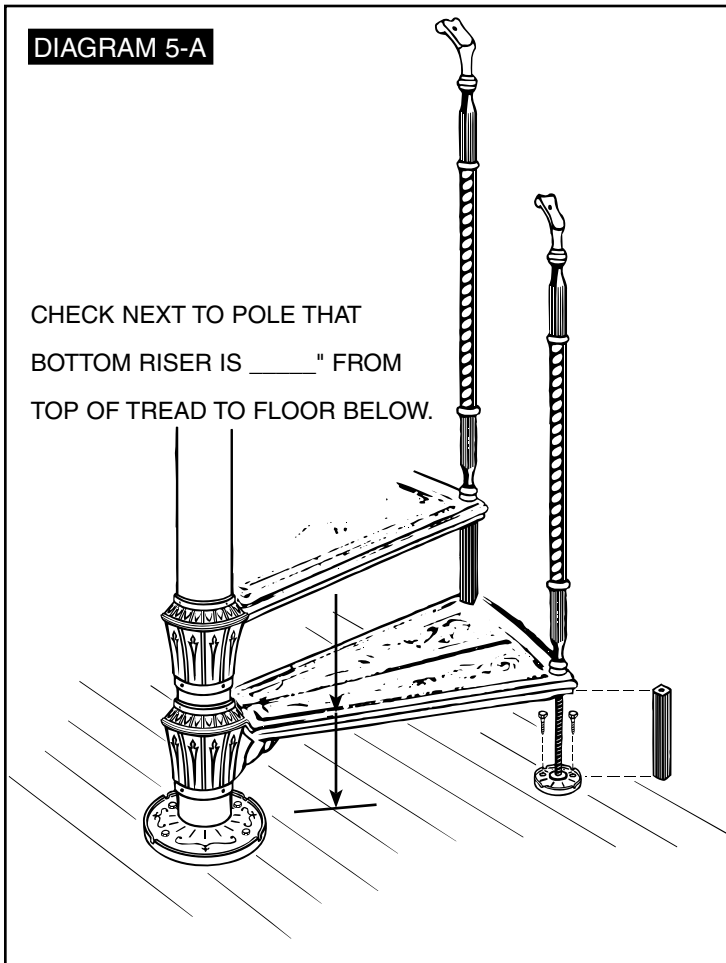

(B.) For wood floors, drill pilot holes with a $\frac{7}{32}$ " drill bit using the base plate holes as the guide. Secure the spindle base plate with two 2" long lag bolts.

For masonry or concrete floors, mark the two hole positions on the floor. Disassemble the starting spindle, spacer and base plate. Drill holes 2" deep using a $\frac{3}{8}$ " diameter carbide tip masonry bit. Clean out the holes and insert rawl fiber expansion plugs. Reassemble the starting spindle, spacer and base plate. Make sure the base plate holes are directly over the plugs and fasten the plate with two 2" long lag bolts.

(C.) Tighten all four set screws in the bottom tread's hub.

STEP #6 - Handrail (Aluminum or Brass):

Note: The handrail coil has been annealed to remove temper, making it softer and easier to form to the stair. It is necessary to work with the coil on a soft surface such as carpet or cardboard. **DO NOT USE ANY TOOLS, CLAMPS OR HAMMERS, AS THEY WILL DENT THE HANDRAIL.**

(A.) Remove the protective plastic sleeve from the coil. Enlarge the diameter of the coil to 6" larger than the stair diameter, by standing it up on edge and **gently and uniformly** pulling it away from the center as someone holds the other side. Continue all around the coil.

(B.) Determine if your installation is left or right hand up. (**Left hand up**—when your left hand would hold on to the handrail as you walk up the stairway. **Right hand up**—when your right hand would hold the handrail as you walk up the stairway.)

(C.) If your stairway is left hand up. Stand the coil up on its edge with the open ends at the top. Grasp with your left hand, the end of the coil that allows your thumb of your left hand to be next to the end of the rail. Your helper should face you on the other side of the coil. Your helper should grasp the other end of the rail with their left hand, so that the coil end is next to their left thumb. **SEE DIAGRAM 6-A**

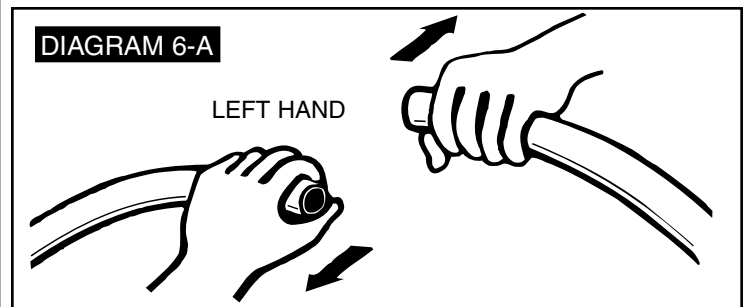

If your stairway is right hand up. Stand the coil up on its edge with the open ends at the top. Grasp with your right hand, the end of the coil that allows your thumb of your right hand to be next to the end of the rail. Your helper should face you on the other side of the coil. Your helper should grasp the other end of the rail with their right hand, so that the coil end is next to their right thumb. **SEE DIAGRAM 6-B**

THE IRON SHOP®

The Leading Manufacturer of Spiral Stair Kits®

VICTORIAN ONE ASSEMBLY PROCEDURE

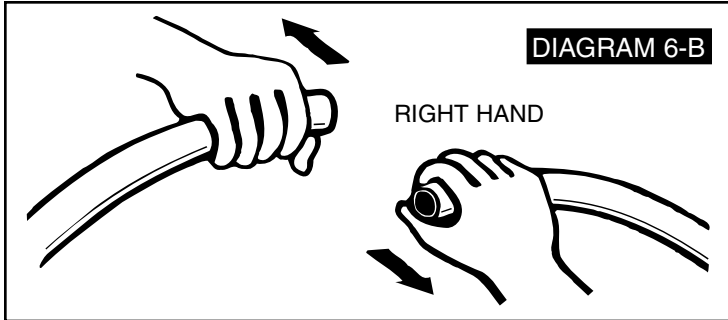

(D.) Walk slowly away from each other, stretching the coil uniformly into a large spring-like shape. This is accomplished by pulling outward and upward with the end of the coil. It is important that you do not pull the coil apart at one point only, as this will cause the coil to kink. As you are pulling the coil apart you must also rotate the coil with yourself and your partner walking towards each other meeting at the center of the coil. **SEE DIAGRAM 6-C & 6-D**

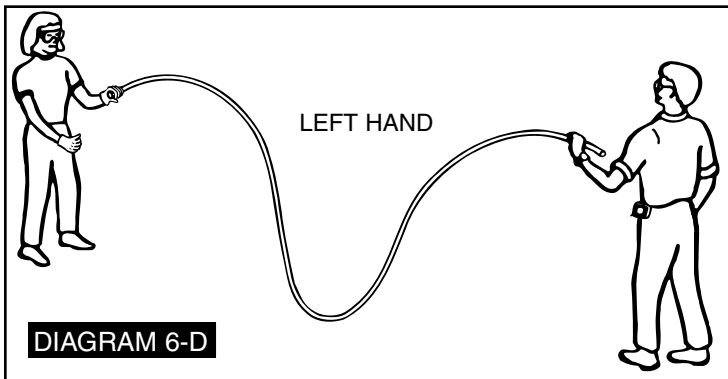
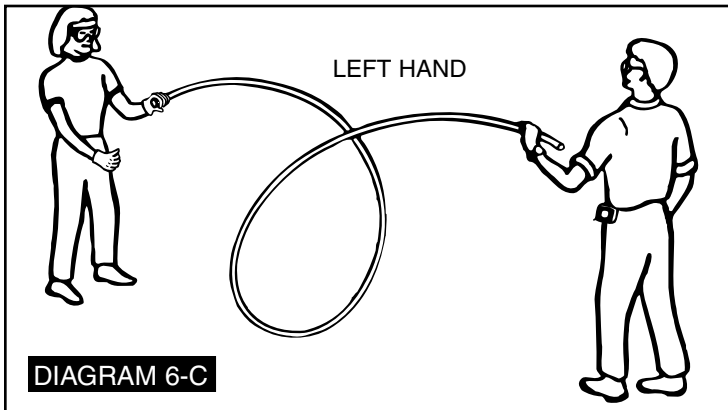

(E.) Check the handrail for fit on the staircase by winding it up the staircase and letting it touch the nosing of each tread at the inside edge of the railing

spindle. Remember that as you attach the railing to the staircase in the following steps, you can move the coil the additional amount necessary for a proper fit.

(F.) Raise the handrail and let it rest on the spindle brackets. (At this stage the railing probably will not align perfectly with all of the spindle brackets.)

Suggestion: *Fitting will be easier, if you are at the top, a helper is halfway up and another helper is at the bottom.*

(G.) Start by positioning the bottom end of the handrail so that it overhangs the bottom spindle by 6".

SEE DIAGRAM 6-E

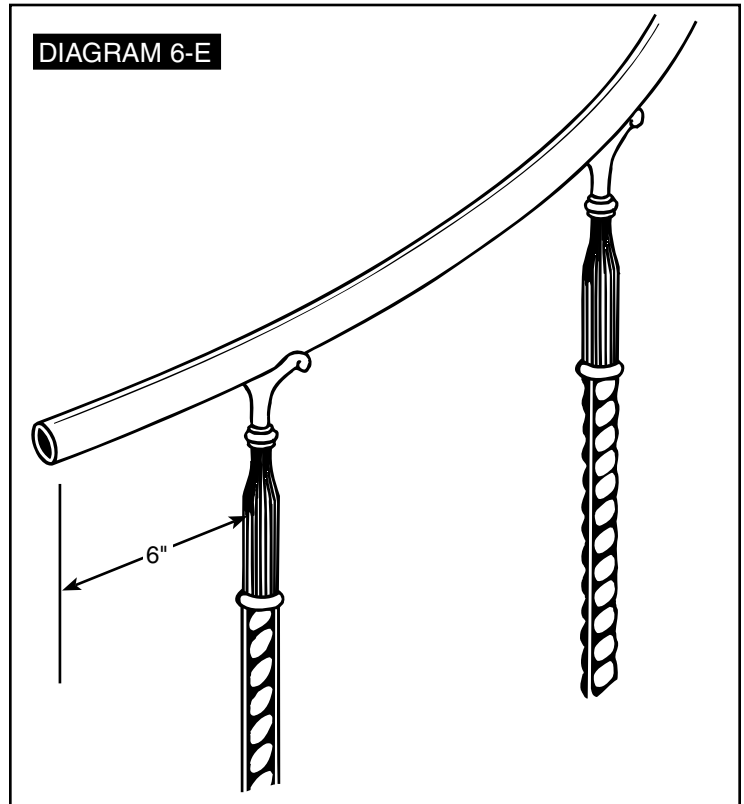

(H.) Fit the rail so that it seats into the bottom spindle bracket and lines up with the next two or three spindle brackets.

Suggestion: *To help keep the handrail in place during the drilling process, wrap $\frac{3}{4}$ " masking tape around the handrail and spindle brackets wherever they meet.*

THE IRON SHOP®

The Leading Manufacturer of Spiral Stair Kits®

VICTORIAN ONE ASSEMBLY PROCEDURE

(I.) Set your $\frac{3}{64}$ " drill bit into the chuck, so that it protrudes by only one inch. (This will prevent the drill bit from denting or cutting through the top of the handrail during drilling.) Drill a $\frac{3}{64}$ " pilot hole through the underside of the handrail only, using the bracket hole in the bottom spindle as your drill bit guide, making sure to drill at a 90° angle to the handrail. Check that the spindle is plumb and secure it to the handrail with a #10 x $\frac{3}{4}$ " pan head sheet metal screw. **SEE DIAGRAM 6-F**

DIAGRAM 6-F

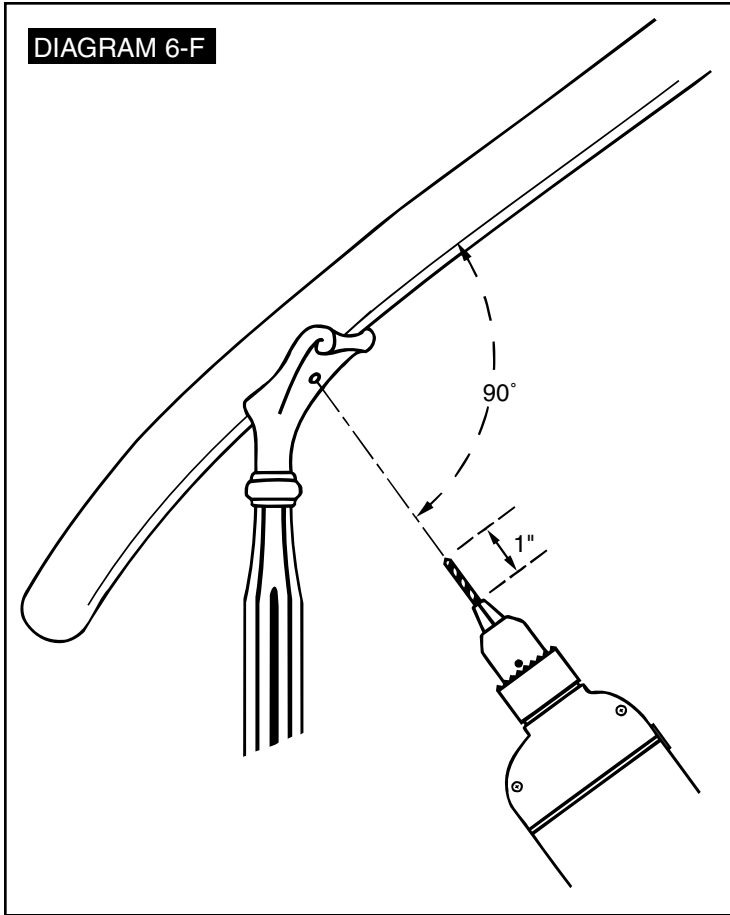

(J.) Position the rail over the second and third spindles and secure using the same procedure as **STEP 6-I**, making sure that the spindles remain plumb. It may be necessary to move the handrail to seat it into each spindle bracket. This can be done by moving several steps up and using leverage while your assistant holds the completed area in place. **Keep checking that all spindles remain plumb during the forming process.**

(K.) Repeat this procedure for all of the remaining spindles.

(L.) Satin finish the handrail by vigorously rubbing in the direction of the handrail with fine emery paper, steel wool, or nylon scrubbing pads. Your aluminum or brass polish can be used for a finished luster.

Hint: To help keep the brass handrail from tarnishing—after it is polished, coat the handrail with a clear furniture wax and buff with a clean dry cloth.

STEP #7 - Handrail End Scrolls:

(A.) Position a handrail end scroll along the outside of the bottom end of the handrail, so that the plug end of the scroll is parallel to the handrail, and the ball end lines up with the front edge of the bottom spindle. Make a mark on the railing at the point where the plug of the scroll and the end of the scroll meet. Continue the line around the perimeter of the railing at a 90° angle to the handrail.

Suggestion: Use a piece of flexible plastic, a stiff piece of paper or masking tape to form a guide for marking the line at the proper angle throughout the circle.

Using your hacksaw, follow the marked line carefully to cut the excess length from the handrail. File smooth any rough edges. **SEE DIAGRAM 7-A**

THE IRON SHOP®

The Leading Manufacturer of Spiral Stair Kits®

VICTORIAN ONE ASSEMBLY PROCEDURE

DIAGRAM 7-A

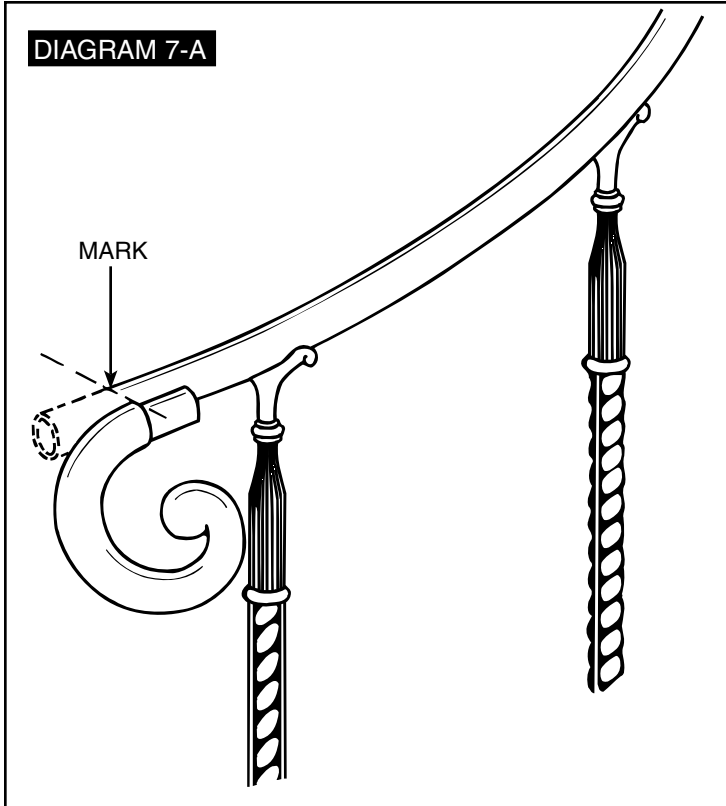

(B.) Insert the plug end of the handrail end scroll into the end of the handrail. From the underside of the handrail, approximately $\frac{1}{2}$ " back from the cut, drill an $\frac{1}{64}$ " hole through the handrail and into the plug $\frac{3}{4}$ " deep. Secure in place with a #10 x $\frac{3}{4}$ " pan head, self tapping screw. **SEE DIAGRAM 7-B**

Accessory Note: If you ordered your Kit with the optional balcony railing please refer to Page 19 for additional instructions on installing the handrails top "goose neck".

DIAGRAM 7-B

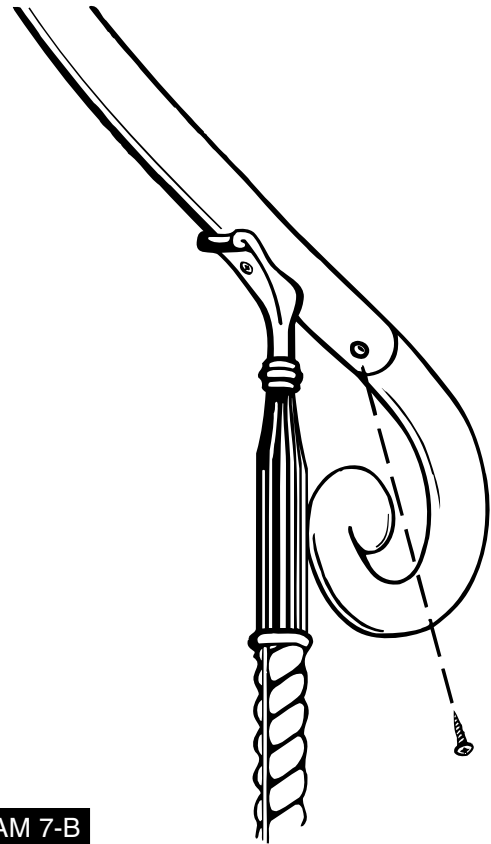

(C.) To install the top handrail scroll end, hold it along the side of the handrail so that the plug end is parallel to the handrail and the ball end touches the back edge of the top spindle. Follow the instructions for marking and cutting as described in **STEP #7-A**. **Be careful that the point where you cut the railing is beyond the top spindle bracket.** Remove the screw from the top spindle bracket. Insert the plug end of the handrail end scroll into the railing and align the ball end with the center of the top spindle. Determine the drilling point on the plug by inserting an ink marker through the bracket and railing holes. Remove the scroll end and drill an $\frac{1}{64}$ " hole approximately $\frac{3}{4}$ " deep into the mark on the plug. Turn the self tapping screw into the hole in the plug, to cut the threads, and then remove. Reinsert the plug end of the bracket into the handrail, align the ball end with the spindle, and check that the spindle is plumb. Fasten the three parts together using the same self-tapping screw. **SEE DIAGRAM 7-C**

THE IRON SHOP®

The Leading Manufacturer of Spiral Stair Kits®

VICTORIAN ONE ASSEMBLY PROCEDURE

Suggestion: An offset screwdriver will be helpful to tighten the screw.

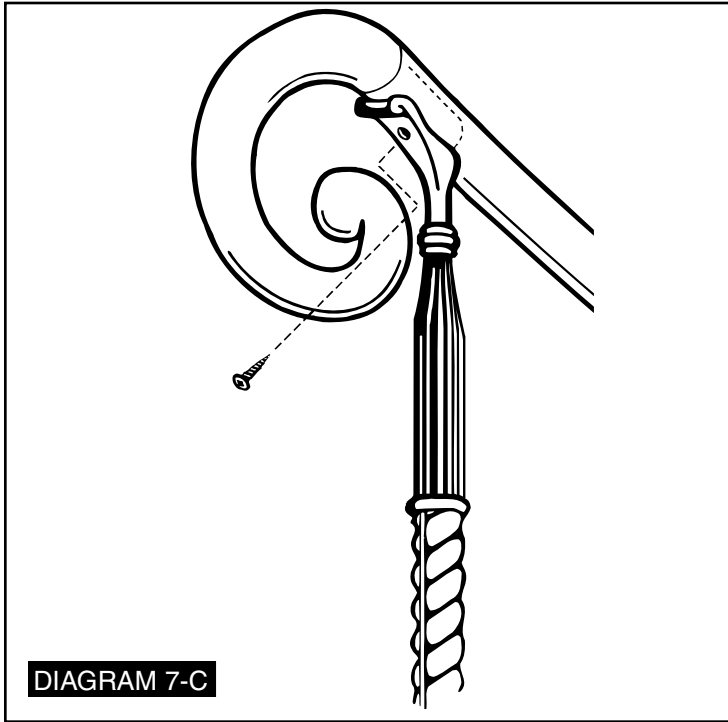
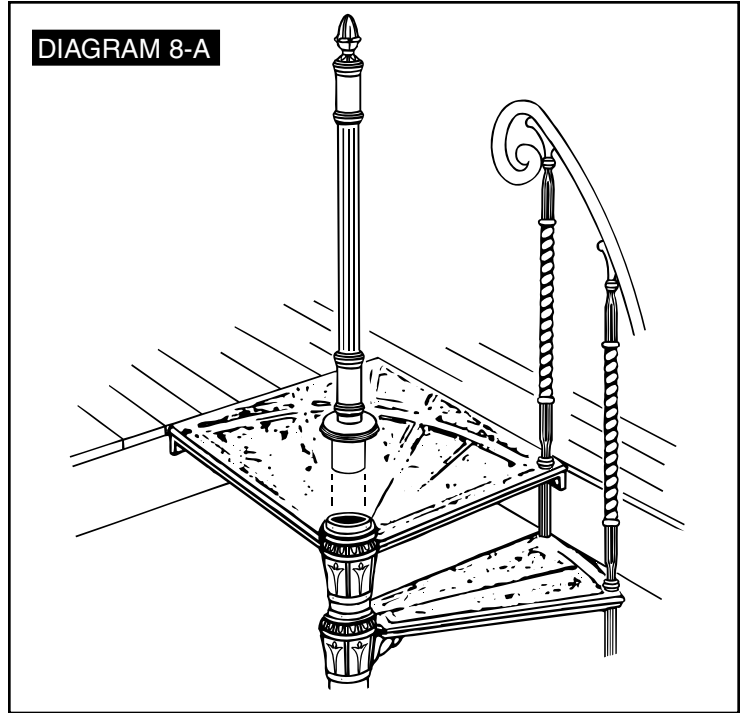

DIAGRAM 8-A



STEP #8 - Landing Railing & Post:

(A.) Set the post into the hole in the center pole. Make sure that the lip of the landing post adapter is seated snugly on the top of the landing hub. **SEE DIAGRAM 8-A**

(B.) Carefully drill a hole with a $\frac{7}{32}$ " bit through the side of the hub facing the landing. Continue drilling through the wall of the center pole, landing post adapter, and post. **Be sure to hold the drill level at a 90° angle to the top post while drilling.** Screw a $\frac{1}{4}$ " x 2" self tapping screw into the hole to lock the post in place. **SEE DIAGRAM 8-B**

DIAGRAM 8-B

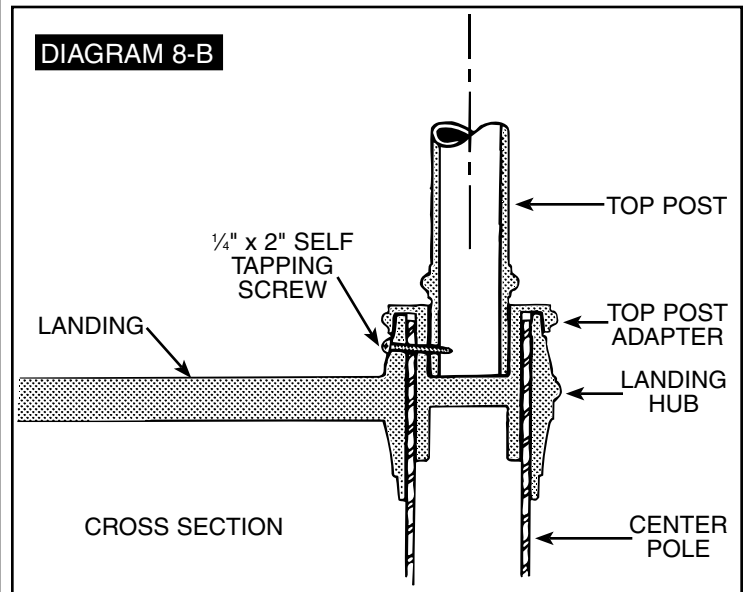

THE IRON SHOP®

The Leading Manufacturer of Spiral Stair Kits®

VICTORIAN ONE ASSEMBLY PROCEDURE

(C.) The standard length landing rail (24" long for the 4'0" diameter Kit, 30" long for the 5'0" diameter Kit, 36" long for the 6'0" diameter Kit) is designed to fit the distance between the landing post and an optional aluminum post centered 3" out from the edge of the well opening. (See your shop drawings for length.)

*Note: If the other end of the railing is to be attached to a wall or your own post or well rail system, you may have to trim the top and bottom rails. If the length to be trimmed is more than 1/2", remove **half** of the amount to be shortened from **each** end to keep the appearance balanced. For example, if the excess length is 2", remove 1" from the top and bottom rails at each end. Mark carefully and saw off the excess using a hacksaw.*

(D.) Slide a mounting bracket on the top and bottom rails at one end of the landing railing. Make sure the end of the top bracket faces down and the bottom bracket faces up. Drill a 1/8" pilot hole through the top bracket in the underside of the top rail and another pilot hole through the bottom bracket into the upper side of the bottom rail. Secure each bracket with a #10 x 3/4" pan head self tapping screw. **SEE DIAGRAM 8-C**

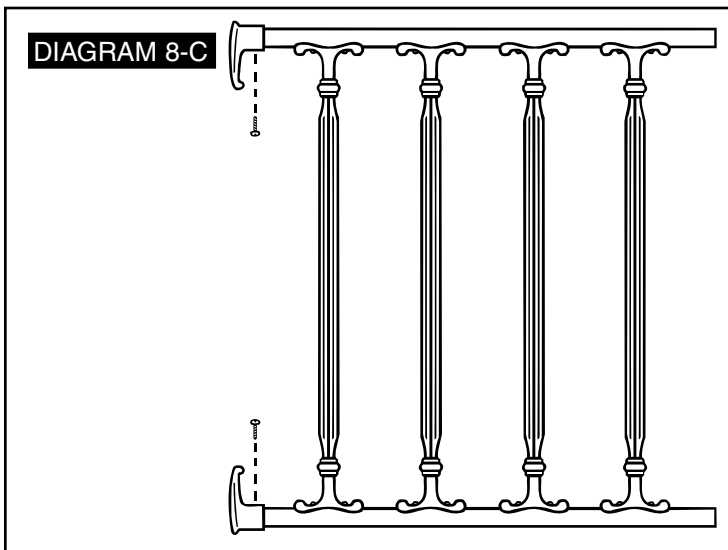

(E.) Slide the remaining mounting brackets on the other end of each rail. With a helper, hold the end of the landing railing with the attached brackets against the landing post and the other end against the wall or post

to which it will be fastened. **Position it so that the top of the railing is 36" above the landing and is parallel to the edge of the landing.** Adjust the position of the unfastened bracket, if needed. Mark the bracket hole locations on the top and bottom rails and attach the brackets as described in **STEP #8-D**.

(F.) Secure the landing rail to the landing post by drilling 5/32" pilot holes into the post, using the holes in the rail brackets as your drilling guide.

Note: You will need a helper to hold the railing in place while you drill and fasten. Make certain that the railing is held level with the upper edge of the top rail 36" above the landing.

Fasten the landing railing to the landing post using #12 x 3/4" self tapping screws. Repeat this procedure at the opposite end of the railing if you are securing to an optional aluminum post. If you are attaching to a wall or wood post, use the longer #10 x 1 1/2" screws provided. **SEE DIAGRAM 8-D**

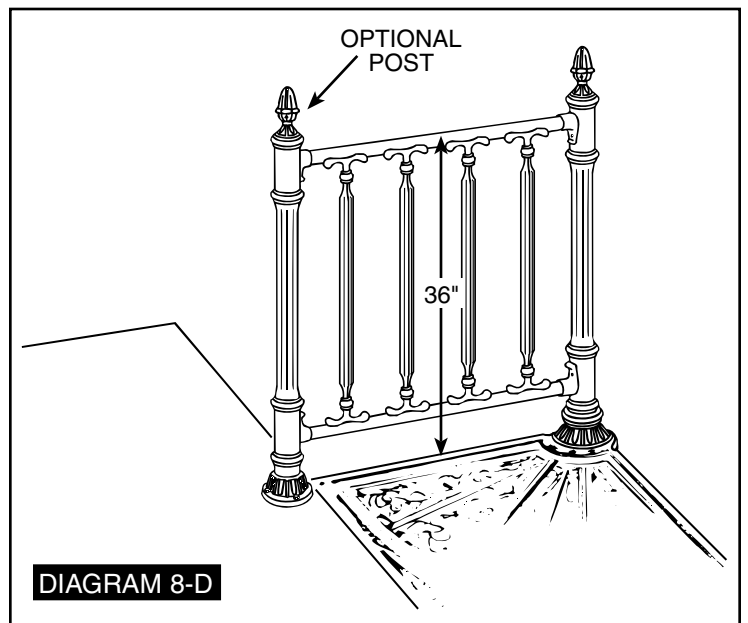

STEP #9 - Finishing:

See the following headings for the appropriate finishing instructions for your particular stair:



The Leading Manufacturer of Spiral Stair Kits®

VICTORIAN ONE ASSEMBLY / ACCESSORIES

Standard Prime Coat Finish Only:

Prep the handrail for painting by first lightly sanding with a medium to fine sandpaper. Wipe down with a clean cloth to remove all dust. Paint the handrail with the special aluminum prep wash primer supplied, and permit to thoroughly dry.

Paint the entire stair and primed handrail using a high quality oil based enamel made for coating metal products. **DO NOT USE A LATEX WATER BASED PAINT.**

Optional Powder Coated Finish:

Touch up any scratches on stair, handrail, uncoated bolts, screw heads, and acorn nuts with the paint supplied.

Optional “Antique” Baked Finish:

Prep the handrail for painting by first lightly sanding with a medium to fine sandpaper. Wipe down with a clean cloth to remove all dust. Paint the handrail with the special aluminum prep-wash primer supplied, and permit to thoroughly dry.

After the primer has thoroughly dried, paint the handrail with the “background” color enamel supplied. When the base color is completely dry, you can apply the “antique” color. To create the antique effect, use a clean 1" wide brush. Dip just the tip of the bristles into the antique color and lightly brush in the direction of the handrail. **Do not apply the paint evenly—just dab and highlight areas. Try to match the appearance of the other parts of the Stair Kit.** To finish the rest of the stair, touch up any scratches and uncoated bolts, screw heads, and acorn nuts with the “background” color. When thoroughly dry, dab with the “antique” color where appropriate.

WELL RAILS

Note: Refer to the shop drawing of the optional well rail(s) that came with your Kit for your specific layout. All optional well rails are custom cut for their specific job.

Note: Normal positioning of all posts and rails is so that their center line is 3" from the edge of the opening.

STEP #1:

Temporarily layout the post(s) and panel(s) as per the shop drawing to verify the positioning.

STEP #2:

Attach the rail brackets to the ends of the panel(s) with the #10 x 3/4" self tapping screws supplied.

STEP #3:

Install the post(s) per the shop drawing. Trace the bolt holes on the floor. If your floor is wood, drill 7/32" pilot holes and then fasten the posts with the 1/4" x 2" lag screws provided. If your floor is concrete, use a 3/8" carbide tip masonry drill bit and drill holes 2" deep. Clean out the holes and insert four 2" rawl fiber expansion plugs. Fasten post(s) with the 1/4" x 2" lag screws provided.

STEP #4:

Attach panel(s) to post(s) or wall with #12 x 3/4" slotted hex-head self tapping screws. Position panel(s) so that the top rail is 36" above the floor level.

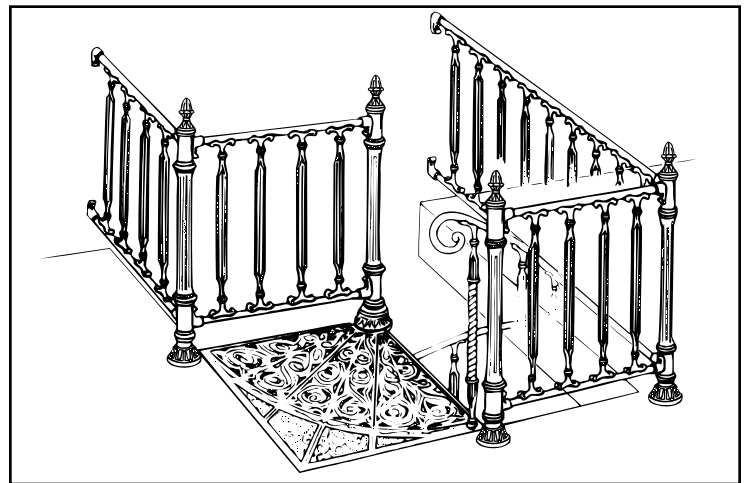

THE IRON SHOP®

The Leading Manufacturer of Spiral Stair Kits®

VICTORIAN ONE ACCESSORIES

SCROLL TREAD ENDS

STEP #1:

The scroll tread end and the tread spacer have been cast in one piece. This combination takes the place of the standard tread spacer and must be installed while the stair is being assembled.

Refer to *Page 7, STEP #3* for additional instructions.

STEP #2:

Check the shop drawing for your Kit so that you use the correct height scroll tread end and tread spacer, where it is required.

STEP #3:

Align so that the top end of the scroll with the protruding stud fits into the recessed pocket cast into the underside of the landing and treads.

SEE *DIAGRAM 1*

4'0" DIAMETER
DESIGN

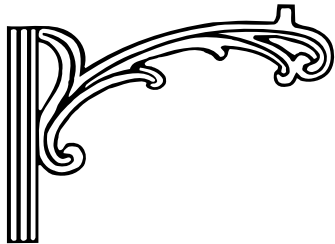

5'0" DIAMETER
DESIGN



6'0" DIAMETER
DESIGN

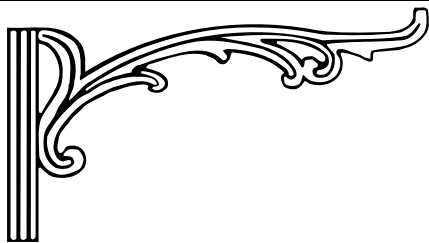
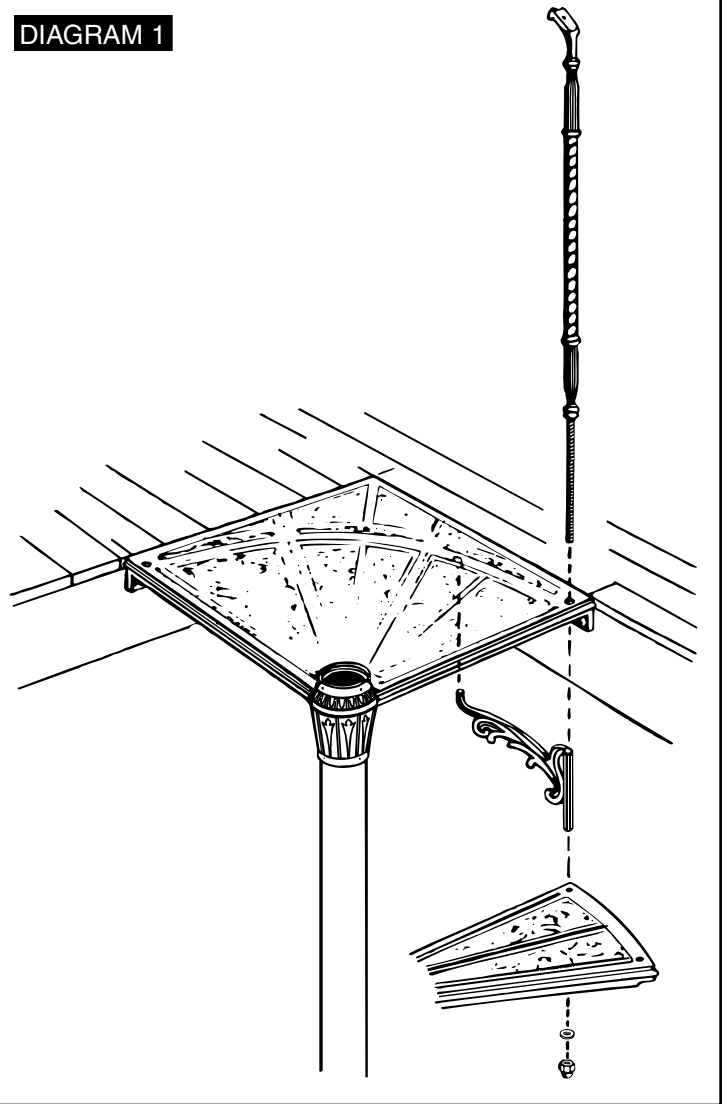

DIAGRAM 1



THE IRON SHOP®

The Leading Manufacturer of Spiral Stair Kits®

VICTORIAN ONE ACCESSORIES

SOLID OAK HANDRAIL

Note: If your Kit came with the optional in-between spindles, they are installed AFTER the solid oak handrail is attached to the standard spindles.

STEP #1:

Find the section of handrail that has the top end without the rail bolt access hole or special stud bolt and place this section on top of the spindles allowing two to three inches of overhang past the top spindle.

STEP #2:

Loosely secure the next section of handrail (the one with a stud bolt and access holes at each end) by having a helper hold the top section while you engage the threaded stud into the special ball nut. Make certain that the threaded portion of the ball nut is facing the stud bolt and turn the ball nut using the small wrench provided. The handrail should be resting on top of the stair spindles.

Loosely secure the remaining section(s) in the same manner.

STEP #3:

Check the location of the access holes under the rail to make certain that none are blocked by spindles (or if your Kit has in-between spindles, check the location of the access holes where the in-between spindles will mount) and shift the rail up or down to position the access holes so they are all accessible and are not where a spindle will screw to the handrail. Make certain that you leave a few inches of overhang at the top and bottom.

Note: If your Kit has a balcony landing railing that will connect to the handrail see the special instructions that came with your Kit to show how to make this connection using the special "goose-neck."

STEP #4:

Check the top spindle for plumb with a level and drill a 1/8" pilot hole through the hole on top of the spindle into the handrail. Keep pressure on top of the handrail so that the rail remains seated on the spindle. Secure with the #10 x 2" long flat head screws provided. Continue attaching the spindles working down to the first handrail joint. Checking each spindle for plumb.

STEP #5:

Examine the first handrail joint. It may be necessary to align the joint by sanding the end of the next section until the joint is properly aligned. Spread a thin film of glue on the end of the next section and rethread the ball nut and tighten completely making certain that the next section is seated on top of the spindles and securing the joints until all of the spindles are completed. Checking each spindle for plumb.

STEP #6:

Trim the ends, of the handrail, so that two inches of it overhang the top and bottom spindles, cut the ends square. Spread a thin film of glue on an end cap and center it on the end of the rail. Drill a pilot hole and screw on the cap. Glue a wood button on the hole in the end cap and sand it flush with the cap, if desired.

Note: If your Kit has a balcony landing rail that will connect to the handrail see the special instructions that came with your Kit to show how to make this connection using the special "goose-neck." No cap is mounted to the top of the handrail with this option.

THE IRON SHOP®

The Leading Manufacturer of Spiral Stair Kits®

VICTORIAN ONE ACCESSORIES

IN-BETWEEN SPINDLES

Note: Single, double, or triple in-between spindles are installed after the stair has been assembled and the handrail has been secured in place. These spindles have been cut to the height required according to your floor-to-floor and riser heights.

Single In-Between Spindles:

Place spindle in the middle of each tread by securing from the underside with the $\frac{1}{4}$ " bolts supplied. Make sure that the top handrail bracket fits the underside of the handrail. Check spindle with your level to keep it plumb. Drill a $\frac{1}{8}$ " pilot hole through the underside of the handrail only—using the bracket hole as your drill bit guide. Secure to handrail with a #10 x $\frac{3}{4}$ " pan head sheet metal screw and lock washer. **SEE DIAGRAM 1**

Double In-Between Spindles:

The in-between spindles have been cut to two different lengths. The shorter one is bolted from the underside of the hole closest to the front or leading edge of the tread—using the $\frac{1}{4}$ " bolts supplied. The longer one is bolted from the underside of the hole towards the back edge of the tread. Before tightening, make sure that the top handrail bracket of the spindle aligns with the handrail. Check spindle with your level to keep it plumb. Drill a $\frac{1}{8}$ " pilot hole through the underside of the handrail only—using the bracket hole as your drill bit guide. Secure to handrail with a #10 x $\frac{3}{4}$ " pan head sheet metal screw and lock washer. **SEE DIAGRAM 2**

Triple In-Between Spindles:

The in-between spindles have been cut to three different lengths. The shortest one is bolted from the underside of the hole closest to the leading edge of the tread—using the $\frac{1}{4}$ " bolts supplied. The middle length is bolted from the underside to the middle hole. The longest one is bolted from the underside of the hole towards the back of the tread. Before tightening, make sure that the top handrail bracket of the spindle aligns with the handrail. Check spindle with your level to keep it plumb. Drill a $\frac{1}{8}$ " pilot hole through the underside of the handrail only—using the bracket hole as your drill bit guide. Secure to handrail with a #10 x $\frac{3}{4}$ " pan head sheet metal screw and lock washer.

DIAGRAM 1

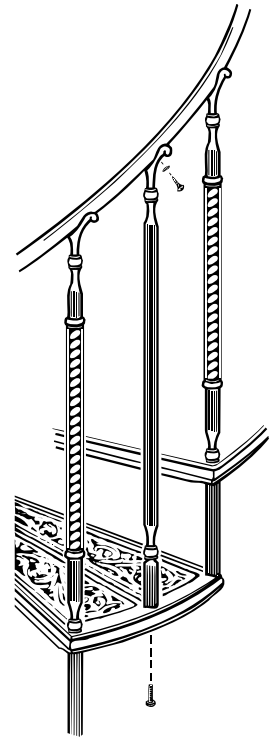
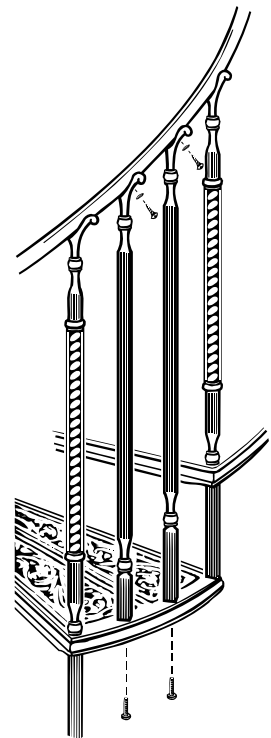

DIAGRAM 2



THE IRON SHOP®

The Leading Manufacturer of Spiral Stair Kits®

VICTORIAN ONE ACCESSORIES

BALCONY RAILING

STEP #1 - Continuation of STEP #3-A, on Page 7:

(A.) A post with a special balcony condition base flange takes the place of the top railing spindle. Position the post and flange over the edge of the landing, so that the hole in the base of the flange and the one in the leading edge of the landing align. Prepare the ½" threaded rod with a lock washer and acorn nut turned onto one end.

Raise the last tread that was lowered down the pole and position it so that the threaded rod—with the top tread spacer or combination scroll tread end and spacer—will go up from the bottom of the tread's rear spindle hole through the spacer and landing into the post flange and lightly tighten. *SEE DIAGRAM 1*

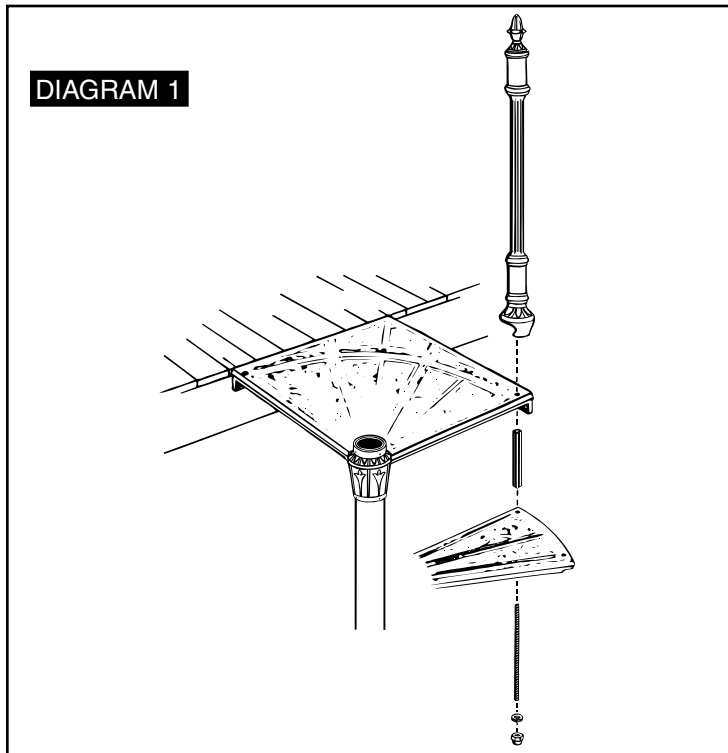

(B.) Check the post and tread with your level to make sure they are plumb and level. Rotate the tread from front to back while plumbing. Also, position the tread spacer so that the fluting matches the direction of the railing spindles. Tighten the acorn nut and check the tread for level. Tighten the top two set screws of the hub, making sure that the tread remains level, then tighten the bottom two set screws.

Continue assembly with STEP #4, on Page 8.

STEP #2 -Continuation of STEP #7-B, on Page 12:

A “goose neck” handrail fitting takes place of the top railing scroll. To install the top “goose neck”, hold it along the side of the handrail, so that the plug end is parallel to the handrail and the bracket is against the smooth round section at the top of the post. Mark and cut the handrail so as to provide a tight seam. With the “goose neck” in position, drill a ⅛" hole through the underside of the handrail into the plug approximately ¾" deep. You may want to ream this hole slightly larger, so that the #10 x ¾" self tapping screw can be easily tightened into the hole. Mark the hole required through the top bracket against the post. Remove the “goose neck” bracket so that the hole can be drilled into the post. After drilling, reposition and secure at both locations. *SEE DIAGRAM 2*

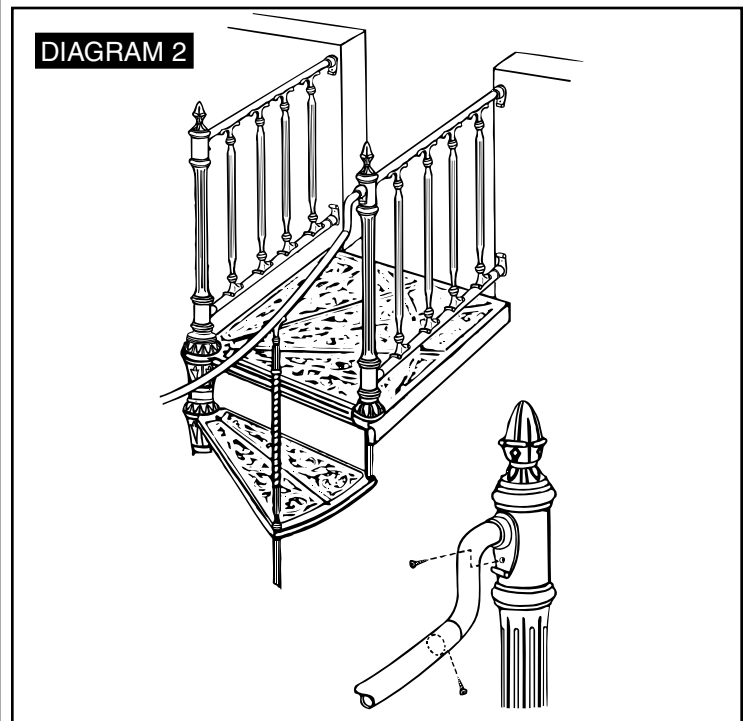

Continue assembly with STEP #8, on Page 13, to position and mount the landing railing.

THE IRON SHOP®

The Leading Manufacturer of Spiral Stair Kits®

VICTORIAN ONE INSTALLATION MANUAL



Since 1931, The Iron Shop has enjoyed a reputation for outstanding design and fabrication of custom built spiral, curved, and floating stairs. With the introduction of our Spiral Stair Kits in 1972, The Iron Shop's quality and value became available for the first time on a national basis. Today, we utilize computer-aided technology throughout our production process to guarantee that each stair meets exacting standards—successfully mixing state-of-the-art manufacturing with old-world quality.

Offering the largest selection, highest quality, and lowest prices in spiral stairs—we make sure that you get the right spiral to meet your needs. This has made The Iron Shop the leading manufacturer of spiral stair kits, with over one hundred thousand satisfied customers worldwide. And our stairs are still made with pride in the U.S.A.

Main Plant & Showroom

Pennsylvania
P.O. Box 547
400 Reed Road
Broomall, PA 19008
Tel: (610) 544-7100
Fax: (610) 544-7297
1-800-523-7427

Other Showroom/Warehouse Locations

California
Ontario Pacific Bus. Ctr.
P.O. Box 3008
3949 Guasti Rd. Unit D
Ontario, CA 91761
Tel: (909) 605-1000
Fax: (909) 605-8899
1-800-382-IRON (4766)

Florida
Sarasota Business Center
752 Commerce Dr., Ste. 1
Venice, FL 34292
Tel: (941) 484-7577
Fax: (941) 484-7115
1-800-648-6990

Regional Sales Office

Texas
Tel: (713) 789-0648
Fax: (713) 789-0720
1-800-438-IRON (4766)

The Stairway Shop Locations

Louisiana
5717 Salmen Street
New Orleans, LA 70123
Tel: (504) 734-1315
Fax: (504) 733-0379

Ohio
262 Business Center Dr.
Blacklick, OH 43004
Tel: (614) 575-9640
Fax: (614) 575-9644

www.TheIronShop.com • e-mail: info@TheIronShop.com

All illustrations and specifications are based upon the latest product information available at the time of printing. The Iron Shop reserves the right to make changes at anytime without notice, in specifications, materials, and models.

THE IRON SHOP®
The Leading Manufacturer of Spiral Stair Kits®

The Iron Shop® is a registered trademark of M. Cohen & Sons, Inc. d.b.a. The Iron Shop

© 2014 The Iron Shop
Printed in the U.S.A