

(THESE NOTES SHALL APPLY UNLESS OTHERWISE NOTED)
NOTE: WHERE CODE IS SPECIFIED, IT SHALL BE THE CITY OF SAN DIEGO MUNICIPAL CODE, 2022 CALIFORNIA RESIDENTIAL CODE, AND 2021 INTERNATIONAL BUILDING CODE.

- 1. CONTRACTOR SHALL VERIFY ALL CONDITIONS AND DIMENSIONS AT THE JOB SITE.
2. SOIL BEARING MINIMUM = 1,500 P.S.F. PER TABLE 1808.2 FOR CLAY, SANDY CLAY, SILTY CLAY, CLAYEY SILT, SILT AND SANDY SILT PER GRADING PRE-INSPECTION OR SOILS REPORT.
3. CONCRETE FOR NEW FOOTINGS SHALL BE STANDARD MIX, 2,500 P.S.I. AT 28 DAYS. DEPUTY INSPECTOR NOT REQUIRED.
4. STRUCTURAL STEEL PLATES AND BARS SHALL BE A.S.T.M. A-36 (OR HIGHER) YIELD STRENGTH ALUMINUM PLATE FOR TREADS SHALL BE 5052-H32. ALL OTHER PLATE SHALL BE 6061-T6.
5. STEEL PIPE COLUMNS AND SLEEVES SHALL BE A.S.T.M. A-53 GRADE B OR ROUND H.S.S., A.S.T.M. A500 GRADE B ALUMINUM AND ROUND TUBE COLUMNS SHALL BE 6061-T6.
6. STEEL TUBES SHALL BE A.S.T.M. A500 GRADE B. (Fy = 42 K.S.I. MIN.). ALUMINUM TUBES SHALL BE 6061-T6.
7. BARS SHALL BE A.S.T.M. A-307. SET SCREWS SHALL BE A.S.T.M. F912. BOLTS IN ALUMINUM SHALL BE STAINLESS STEEL.
8. FASTENERS FOR EXTERIOR EXPOSURE SHALL BE STAINLESS STEEL FOR STEEL STAIRWAY AND STAINLESS STEEL FOR ALUMINUM STAIRWAY.
9. STEEL WELDING SHALL BE PER CODE USING SHIELDED METAL ARC PROCESS WITH E70XX ELECTRODES OR EQUAL IN AN APPROVED FABRICATOR'S SHOP. ALUMINUM WELDING SHALL BE PER CODE WITH 5358 WELD FILLER.
10. ALL FABRICATION SHALL BE DONE IN THE SHOP OF A LICENSED FABRICATOR OF THE CITY OF LOS ANGELES OR EQUAL.
11. STAIRWAY SHALL BE USED FOR ONE AND TWO FAMILY DWELLING ONLY.
12. SPIRAL STAIRWAYS ARE PERMITTED TO BE USED AS A COMPONENT IN THE MEANS OF EGRESS ONLY WITHIN DWELLING UNITS OR FROM A SPACE NOT MORE THAN 250 SQUARE FEET IN AREA AND SERVING NOT MORE THAN THE OCCUPANCY GROUP 101 TO 103 OF 2022 IBC.
13. PROVIDE: MINIMUM OF 26" WIDE WALKING AREA FROM OUTER EDGE OF SUPPORT COLUMN TO INNER EDGE AT AND BELOW HANDRAIL, 7 1/2" MINIMUM TREAD AT A POINT 12" FROM WHERE THE TREAD IS NARROWEST. MINIMUM 6" HEAD ROOM AND RISE NOT TO EXCEED 5 1/2". STAIR TREADS AND RISERS SHALL BE OF UNIFORM SIZE AND SHAPE. THE TOLERANCE BETWEEN THE LARGEST AND SMALLEST RISER HEIGHT OR BETWEEN THE LARGEST AND SMALLEST TREAD DEPTH SHALL NOT EXCEED 3/8" (0.375 INCH) IN ANY FLIGHT OF STAIRS.
14. THE TOP OF GUARDRAILS (GUARDS) SHALL BE 42" MINIMUM IN HEIGHT. OPEN GUARDRAILS (GUARDS) SHALL HAVE INTERMEDIATE RAILS OR AN ORNAMENTAL PATTERN SUCH THAT A 4" SPHERE CANNOT PASS THROUGH.
15. HANDRAILS SHALL BE CONTINUOUS THROUGH THE FULL LENGTH OF THE STAIRS. FOR PRIVATE STAIRWAYS, HANDRAILS ARE NOT REQUIRED TO EXTEND BEYOND THE TOP OR BOTTOM RISER PER CODE SECTION 1014.6.
16. WINDING AND LANDINGS AT DOORS SHALL COMPLY WITH CODE SECTIONS 1010.1.6 AND 1011.6.
17. REDUCED PLANS OR POOR QUALITY PRINTS (TOO DARK OR TOO LIGHT) WILL NOT BE ACCEPTABLE FOR OBTAINING BUILDING PERMITS.
18. A PLOT PLAN AND/OR FLOOR PLAN IS REQUIRED FOR OBTAINING A BUILDING PERMIT USING THIS PRODUCT.
19. REPRESENTATIONS OF PATTERNS AND VIEWS SHOWN ON THIS PLAN MAY NOT MATCH CURRENT PRODUCTION.
20. ALL WORK MUST COMPLY WITH SAN DIEGO MUNICIPAL CODE AND LOCAL PLANNING AND ZONING CODES WHERE APPLICABLE.
21. STRUCTURAL OBSERVATION IS NOT REQUIRED PER I.C.C.-C.B.C./A.B.C. SECTION 1704.2.5.
22. DESIGN LOADS:
A. LIVE LOADS: 40 P.S.F. OR 300 LB. ON AREA 2 IN. BY 2 IN. ON TREADS & 40 P.S.F. ON LANDING.
B. SPECIAL LOADS: HANDRAIL AND GUARDRAIL (GUARD): 200 LB. IN ANY DIRECTION; INTERMEDIATE RAILS: 50 LB. ON ONE S.D.F.T.
C. SNOW LOADS: Ps = 0.7(1.2)(1.2)(1.0)40 = 40 P.S.F.; Cs = 1.2 (SHeltered (MOST SEVERE FACTOR)); Cw = 1.0 (UNSHeltered (MOST SEVERE FACTOR)); I = 1.0 (RISK CATEGORY I OR II)
D. WIND DESIGN DATA: BASIC WIND SPEED: Vw1 = 125 M.P.H. (3-SECOND GUST, RISK CATEGORY I OR II) AT 33' ABOVE GRADE; Iw = 1.0; Exposure: 'C'; INTERNAL PRESSURE COEFFICIENT: I/A; COMPONENTS AND CLADDING: N/A
NOTE: WHEN STAIRWAY IS USED ON EXTERIOR OF BUILDING, IT SHALL NOT BE LOCATED NEAR HILLS, RIDGES, OR ESCARPMENTS.
E. EARTHQUAKE DESIGN DATA: Ie = 1.0 (RISK CATEGORY I OR II); Ss = 3.75g; S1 = 1.39g; SITE CLASS: D; Sps = 1.00g; S01 = 1.39g; SEISMIC DESIGN CATEGORY: E; SEISMIC FORCE RESISTING SYSTEM: ORDINARY MOMENT FRAME; ANALYSIS PROCEDURE: EQUIVALENT LATERAL FORCE.
NOTE: SEISMIC DRIFT OF SUPPORTING FLOOR AT TOP OF COLUMN MUST BE LIMITED TO 1/2" MAX. IF ALLOWABLE ELASTIC DRIFT IS TO BE GREATER THAN 1/2", CONTACT THE ENGINEERING DEPT. AT THE IRON SHOP FOR FURTHER EVALUATION.
23. ADDITIONAL REQUIREMENTS:
A. RISER MAY HAVE SPACE REDUCTION BAR PER DETAIL 23 OR EQUAL IF REQ'D.
B. OUTDOOR STAIRWAYS SHALL BE CONSTRUCTED SO THAT WATER WILL NOT ACCUMULATE ON WALKING SURFACES. 2% MAXIMUM SLOPE. STAIRWAY SHALL NOT PROJECT INTO ZONE CODE SETBACK.
C. WALKING SURFACES SHALL BE SOLID SURFACES. EXCEPT OPENINGS PERMITTED THAT WILL NOT PASS A 1/2" DIAMETER SPHERE. ELONGATED OPENINGS SHALL BE PERPENDICULAR TO TRAVEL.
D. USABLE SPACE UNDER STAIRS SHALL NOT BE ENCLOSED.
E. ALL INTERIOR AND EXTERIOR STAIRWAYS SHALL BE ILLUMINATED.
F. THE STAIRWAY CONSTRUCTION SHALL NOT RESTRICT A FIVE-FOOT CLEAR AND UNOBSTRUCTED ACCESS TO ANY WATER OR POWER DISTRIBUTION FACILITIES (POWER POLES, PULL-BOXES, TRANSFORMERS, VAULTS, PUMPS, VALVES, METERS, APPURTENANCES, ETC.) OR TO THE LOCATION OF THE HOOR-KUP. THE CONSTRUCTION SHALL NOT BE WITHIN TEN FEET OF ANY POWER LINES—WHETHER OR NOT THE LINES ARE LOCATED ON THE PROPERTY. FAILURE TO COMPLY MAY CAUSE CONSTRUCTION DELAYS AND/OR ADDITIONAL EXPENSES.
24. GREEN BUILDING CODE REQUIREMENTS:
A. ABSORBABLE MATERIALS DELIVERED TO THE CONSTRUCTION SITE SHALL BE PROTECTED FROM RAIN OR OTHER SOURCES OF MOISTURE.
B. ONLY A CITY CERTIFIED HAULER WILL BE USED FOR THE HAULING OF CONSTRUCTION WASTE.
C. ARCHITECTURAL PAINTS AND COATINGS, ADHESIVES, CAULKS AND SEALANTS SHALL COMPLY WITH THE VOLATILE ORGANIC COMPOUND (VOC) LIMITS LISTED IN TABLE 4.504.1-4.504.3.
D. THE MANUFACTURER'S SPECIFICATIONS SHOWING VOC CONTENT FOR ALL APPLICABLE PRODUCTS SHALL BE READILY AVAILABLE AT THE JOB SITE AND BE PROVIDED TO THE FIELD INSPECTOR FOR VERIFICATION.
E. NEW HARDWOOD, LAMINATE, PARTICLE BOARD, AND MEDIUM DENSITY FIBERBOARD COMPOSITE WOOD PRODUCTS USED IN THE INTERIOR OR EXTERIOR OF THE BUILDING SHALL MEET THE FORMALDEHYDE LIMITS LISTED IN TABLE 4.504.5.
F. THE MANUFACTURER'S SPECIFICATIONS SHOWING FORMALDEHYDE CONTENT FOR ALL APPLICABLE WOOD PRODUCTS SHALL BE READILY AVAILABLE AT THE JOB SITE AND BE PROVIDED TO THE FIELD INSPECTOR FOR VERIFICATION.
G. BUILDING MATERIALS WITH VISIBLE SIGNS OF WATER DAMAGE SHALL NOT BE INSTALLED.

TYPICAL RISERS table with columns for RISER HEIGHT and LANDING TO LANDING HT. - "H"

MINIMUM FINISH FRAMED OPENING FOR STAIRS table with columns for STAIR DIA. "D"

FRAME ROUGH OPENING LARGER TO ALLOW FOR FINISH MATERIAL SUCH AS GYP. BD., TRIM, ETC.

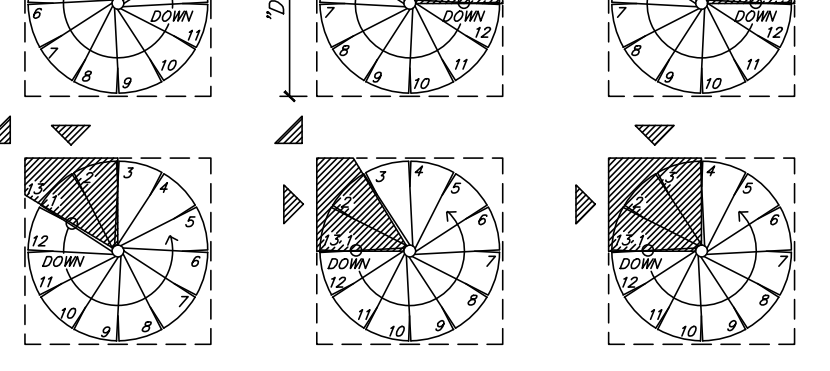

- 1. LANDING IS REVERSIBLE; 60 OR 90 DEGREE EDGE OF LANDING MAY BE USED FOR TOP STEP.
2. 8.625" MINIMUM RISER HEIGHT REQUIRED FOR HEADROOM BELOW 90 DEGREE LANDING.
3. IF DOORWAY OCCURS AT LANDING, A LARGER LANDING MAY BE REQUIRED. SEE NOTE (16) & DETAIL 18.

TREAD & FOOTING SCHEDULE and CENTER COLUMN SCHEDULE tables with columns for STAIR DIAMETER, TREAD, FOOTING, STAIR DIAMETER, PIPE SIZE & TYPE.

LANDING RIB STIFFENER and LANDING RIB TABLE tables with columns for STAIR DIAMETER, STIFFENER SIZE, STEEL, ALUMINUM.

- (1) SEE DETAILS 10 & 8
(2) SEE DETAILS 15 & 20
SOIL BEARING IS ASSUMED TO BE 1500 P.S.F. IF SOIL BEARING VALUE IS GREATER THAN 1500 P.S.F., USE "W" FOR 1500 P.S.F. EXISTING OR NEW CONCRETE FLOOR OR WOOD FLOOR FRAMING SHALL BE DESIGNED BY OTHERS FOR THE SPECIFIC COLUMN LOAD FOR EACH INSTALLATION.
(3) 3-STORY STAIRS (36"-0" MAX. HT. WITH LANDING AT EACH 12"-0").
(4) FOR 6"-6" TO 8"-0" DIA. STAIRS THAT ARE 2 OR 3 STORES, CONCRETE PAD DEPTH OF 14" IS REQUIRED AS OPPOSED TO TYPICAL 12" PAD DEPTH.

